

PREPPER RADIO



v.2026-02-20

User's Manual

INDEX

PREPPER RADIO.....	1
1. INTRO.....	2
2. Firmware.....	3
2.1 Download Firmware.....	3
2.2. PrepperDock.....	3
2.3 Saving Calibration and Original Configuration.....	3
2.4 Flashing the Firmware.....	4
3. Display.....	5
4. Function of keys.....	6
📖 F1 Built-in Guide.....	7
5. Side keys.....	7
6. Menu.....	7
6.1 Channel Config.....	8
6.2 Radio Config.....	9
6.3 Radio FM.....	10
6.4 Messagy.....	10
6.5 Scanny/Spectrum.....	12
6.6 Contacts.....	13
6.7 Timer.....	14
6.8 Info.....	14
7. Common operations.....	14
7.1 Writing module.....	14
7.2 Selective Call.....	15
7.3 DTMF.....	17
8. Practical usage.....	17
8.1 How to get organised.....	17

1. INTRO

PrepperRadio is a remote communication project for **emergency management** from a prepper perspective. It includes the creation of firmware that is installed on QuanSheng [K1](#) and [K5v3](#) radios and the previous [K5](#) (8), K6, Plus, [99](#), 88. PrepperRadio modifies its ergonomics and functionality, simplifying it for those who are not familiar with it and implementing features more similar to a smartphone.

PECULIARITY of PREPPER RADIO

- Compatible with UV-K5, K6, **K1 and K5v3** models.
- Clear and friendly graphical user interface.
- **Built-in Guide**: a reminder of the user manual in the radio itself.
- **Call channel** with ring tone and automatic routing to a conversation channel.
- Number of memories available: **214**.
- **Messagey**: SMS-type messaging.
- **4** scan lists for both channels and frequencies.
- **Scanny**: scanning module that emulates a scanner, including a **Spectrum**.
- **Timer**: alarm clock based on countdown.
- **PrepperDock**: complete management software and open-source.
- **Wiremote**: remote radio control via USB cable and, in future, via Wi-Fi.
- **Radio Calibration**: you can correct the radio calibration via PrepperDock.
- Customisable display contrast.
- Comprehensive **user manuals** and documentation.
- **Dynamic squelch** management that automatically adapts to band type and bandwidth. Exclusive to K5!
- Capable of receiving from 18MHz to 1.3Ghz.



Purchase link for the radio, [Amazon K1](#), [Aliexpress K5v3](#), [Amazon K5](#). And of [Kenwood cable](#).

Everything is legally permitted, there are no encryptions or secrets. The working frequencies are normally for public use. Transmission power is what is provided for the equipment.

What is proposed is to manage possible EMERGENCIES and to save the lives of PEOPLE.

Those who are part of the project are committed to respecting and safeguarding PEOPLE, lives and the rules in force regarding the use of radio and legal frequencies in their country. This firmware is not designed as an ordinary PMR446 Walkie-Talkie.

For those approaching the world of two-way radios for the first time, we recommend reading the: [L'ABC della Radio](#).

This page can also be found in PDF format in PrepperDock.



2. Firmware

2.1 Download Firmware

Last Update: <https://t.me/prepperradio/>

Web site: www.universirius.com/preppers/prepperradio

Inside the ZIP file  PrepperRadio-Full-Pack_v2025-xx-xx.zip you will find the **Readme-ENG.txt** file and all needed to install the firmware, various manuals and procedures to get organised.

◆ Should there be a problem with this firmware, you can always reload the official one and the radio will be exactly as it was before. Please refer to chapter **2.3**.

2.2. PrepperDock

To load the firmware and manage the radio you need the **PrepperDock** software. It runs on Windows , Linux and Mac.

- This software allows you to manage the entire radio, flash the firmware, modify parameters, change channels and save the configuration and calibration data contained in the EEPROM. In fact, it is strongly recommended to do so in the event of a reset.

To connect the radio to the PrepperDock you need a [cable USB Kenwood](#).

AP 2.6

PrepperDock, will soon be part of the Prepper AP distribution starting with version 2.6.0.

2.3 Saving Calibration and Original Configuration

- As mentioned above, it is important to safeguard the original calibration and configuration files. For this you must imperatively use “**k5prog**”:
- Install the cable [driver](#). Ensure that it is well recognized by Windows and k5prog-win.
- → Connect the cable from the computer to the radio, start the radio normally (user mode), start **k5prog_win-v1.26.exe**. Press the ‘Read Configuration’ button, save the configuration file in your folder, repeat the operation with ‘Read Calibration’.
- If you need to restore the radio as it was originally, you just need to restore the original firmware and upload the original configuration and calibration files via **k5prog-win**.

2.4 Flashing the Firmware

1. Make sure you have a battery that is sufficiently charged.
2. Plug the cable into your PC.
3. Connect the cable to the radio. The first time the plugs do not fit very well, you have to push strongly to get them all the way in.
4. Switch on the radio normally.
5. Start the PrepperDock software and open the 'Q Connect' window.
6. Choose the Serial connection and the right COM port for the USB cable.
7. In Automagic Firmware, select 'PrepperDock FW'.
8. Switch the radio on again in update mode:
While pressing the PTT button, switch on the radio. → The white LED lights up.
9. PrepperDock will automatically load the firmware.
→ The firmware loads and the white LED flashes.
10. End of flashing, firmware loading is complete. The radio restarts itself.
11. Back to the main Home window and open the EEPROM window via the EEPROM button. To load the configuration file, press the 'Load Cfg' button and load the named file: Config_PrepperRadio-for_XXXXX.eeprom
This will configure the radio optimally for our PrepperRadio use.
Refer to chapter 2.1 of the user-manual-Come_organizzarsi.pdf.

⚠ For the new **K5 V3 and K1** models, for the first time, you must to load a BandPlan (Config file), tick the "Write Calibration" box and click on "Write All".

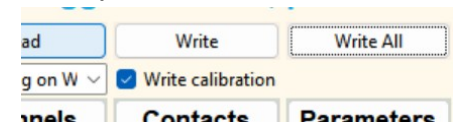

12. If you have not loaded any configuration files, you must load the default Squelch and AGC tables. Section EEPROM > **Squelch**, click on the 'Optimal Squelch Default' and 'Optimal Multiplier Default' buttons, check the 'Write calibration' box at the top and press the 'Write' button. Ditto in the **AGC** tab, load the 'Beken Default' table > SAVE and 'Write'.
13. Switch off the radio and disconnect the cable.
14. Calibrate the battery to avoid the "Volt High" error message.
🔋 Charge fully the battery. With the radio switched on and no cables connected, measure the voltage from the rear contacts. Write down the value to two decimal places, eg: 811 means 8.11 Volts. Press **M** / **MENU** to save, the radio automatically restarts.

- ◆ To connect the radio, you will need a cable [USB programming cable Kenwood](#).
- ◆ Please note that it is not possible to overwrite the calibration part using the PrepperRadio FW.

⚠ ⚠ ⚠ If you are coming from another firmware, first install the original QuanSheng firmware and calibration, do a Reset All, then install PrepperRadio.

3. Display

Main screen

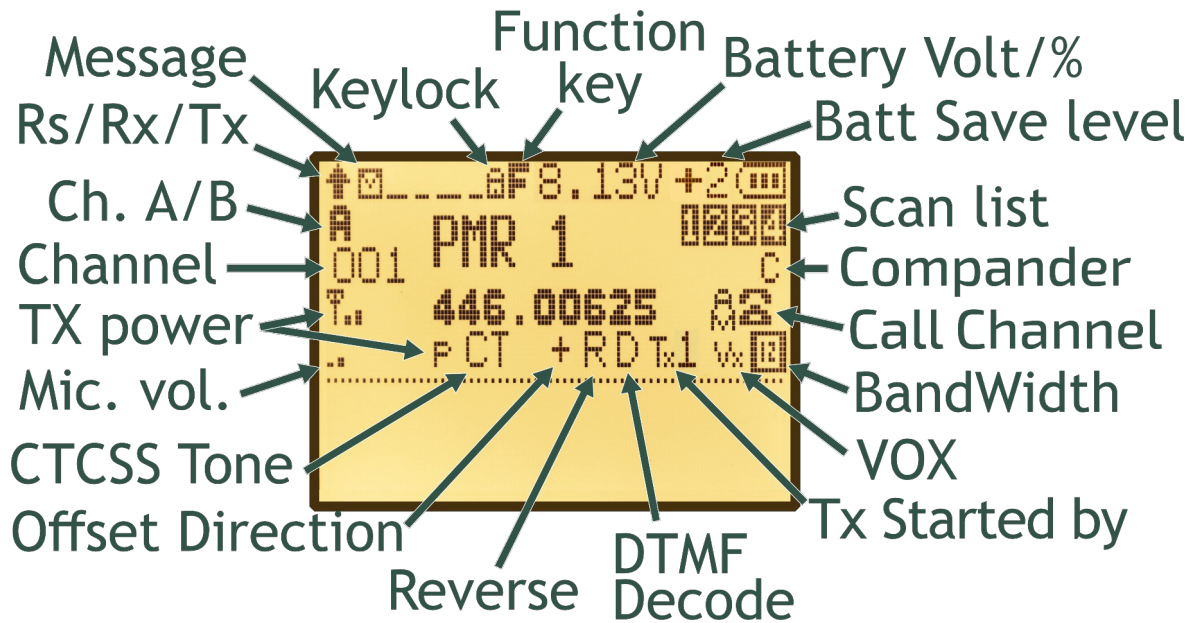

The meaning of icons

	Rs, a dish. Indicates when radio is listening. Absent if radio in Battery Save.
	TX, an arrow pointing in the direction of the antenna.
	RX, an arrow coming from the antenna and going into the radio.
	Letter mail envelope, indicates the presence of messages.
	It shows the activity of the microphone. The chip gives this signal during VOX to understand what it considers voice or silence.
	Save Pending, saving in progress. Whenever the radio saves data, stores a channel or other, its write operation is shown.
	Battery save, a flashing + indicates that Batt Save is active and the battery will last longer.
	AM modulation (<i>only for V3 and K1</i>). Vertically, it looks like the big pylons for AM transmitters.
	The telephone indicates which channel is selected as Call Channel.
	A rectangle that closes tighter and tighter. It indicates the bandwidth. 25k 12.5k 6.25k
	TX Type: 1 = PTT, 2 = Messagy (FSK), 3 = DTMF, 4 = VOX.

4. Function of keys

- ◆ The function of the keys can change depending on which panel you are in.

Function of short-press keys

M (K5) MENU (K1)	Access radio menus . Modify and Memorize settings. In Scanny = Pause. In Message sends message.
EXIT	Goes back through the menus. Stops scanning and FM radio.
* Scan	Activates the string for entering a DTMF sequence. Changes the character in write mode. Switches between Scanny and Spectrum.
F#	Activates the secondary functions of the keys. EXIT to clear it.

Function of long-press keys

F#	Keypad lock. → A padlock appears at the top and the words 'Long F to unlock'.
-----------	---

Function of keys associated with F

F + M MENU	Activates Messagey. Copy the Messagey ID from Contacs to Messagey.
F + 1 Band	Built-in Guide, Help (⚠ <i>V3 and K1 only</i>)
F + 2 A/B	Interchanges between channel A and channel B.
F + 3 VFO/MR	Interchange memory or VFO modes.
F + 4 FC	Recalls the Call channel.
F + 5 NOAA	Clears selective call information.
F + 6 H/M/L	Power selection x p L M H, initials appear below the frequency.
F + 7 VOX	Activates or deactivates VOX. A Vx appears below the frequency.
F + 8 R	(Reverse) In Duplex, inverts RX and TX freq. An R appears below the frequency.
F + 9 Call	Opens the Contact section to make a selective call.
F + * Scan	Opens the Scanny function.
F + 0 FM	Radio FM broadcasting.

- ◆ The VOX must be properly calibrated for one's needs with the PrepperDock programme.
- ◆ It is very important to have the On Busy (Channel Config) option active, which prevents transmission when there is a signal, because you may want to press the PTT while the other party is still talking.

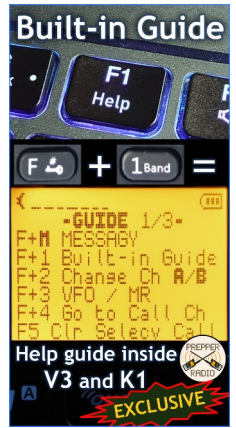

F1 Built-in Guide

The key sequence **F**+**1** displays a guide to the most common functions on the radio. Each section has its own dedicated guide on one or more pages. As this is only a quick reference guide, it is assumed that the user has already read this entire user manual. For more information, read chapter **3.6 Built-in Guide** in the **PrepperDock** manual.

5. Side keys

The two side buttons on the left are programmable via the menu Radio Config → L1Shrt... A function can be assigned to the short or long press.

L1 Short : L = Left key, Short = Short click.

L1 Long: L = Left key, Long = Long press.

L2 Short

L2 Long

Function	Description
FLASH LIGHT	LED lamp. 3 modes: ON, flashing and SOS.
POWER	TX power selection.
Batt Save	Selecting the Batt Save level.
BANDWIDTH	Adjusts the bandwidth.
SEND UPCODE	Send the Up Code.
SEND DWCODE	Send the Down Code.
Clr SelCall	Clears selective call information.
NONE	The key does nothing.

◆ **L1** : In write mode, it deletes the last character.

6. Menu

The Prepper Radio firmware divides the menus into sections:

- Channel Config
- Radio Config
- Radio FM
- Messagy
- Scanny/Spectrum
- Contacts
- Info

To access the sections, enter the menus, enter the selected item and confirm or save your choice, press the **M** / **MENU**.

To exit the menu item without confirming, press the **EXIT**.

To go back one step, press the **EXIT**.

L1 deletes a character (such in Messagy).

 You can quickly access menus and submenus using the corresponding numbers on the keypad.

6.1 Channel Config

These settings will only be stored for the selected channel.

1	Tx Power	x_LPD, p_PMR, LOW, MID, HIGH → x = 0,01 Watt, p = 0,5 Watt, L, M, H.
2	Rx DCS	OFF, D023N, D025N, 26.....754 Sets a DCS code in reception, (208 codes).
3	Tx DCS	OFF, D023N, D025N, 26.....754 Sets a DCS code in transmission, (208 codes).
4	Offset Dir	OFF, +, - Direzione Shift / Offset repeater bridges.
5	Offset	0 to 999.98750 MHz Shift/Offset frequency for repeater bridges.
6	Rx CTCSS	OFF, 67.... 254.1Hz Sets a CTCSS subtone on reception, (50 subtones).
7	Tx CTCSS	OFF, 67.... 254.1Hz Sets a CTCSS subtone on transmission, (50 subtones).
8	Frq Step	kHz: 0.01, 0.05, 0.10, 0.25, 0.50, 1, 1.25, 2.5, 5, 6.25, 8.33, 10, 12.50, 15, 25, 30, 50, 100, 125, 250, 500 Sets the frequency step, i.e. how much will be added (up arrow) or removed (down arrow) to the frequency while in VFO mode.
9	BandWidth	Bandwidth from 6.25k, 12.5k, 25k Set the bandwidth. The correct bandwidth should be used for each emission frequency according to current regulations. 12.5 = Narrow e 25k = Wide.
10	On Busy	OFF, ON, Prevents transmission if the channel is busy. It is recommended to activate it.
11	PTT send	OFF, UP CODE, DOWN CODE. You choose what to send when you press the PTT button.
12	Compander	OFF, TX, RX, RX/TX Compressor/expander filter, improves voice.
13	D Decod	OFF, ON, Activates DTMF decoding. A D appears below the frequency.
14	ScanList	OFF, 1, 2, 3,4. Set scan list to channel. Press buttons 1 and/or 2 and 3 to insert or remove the channel in a scan list.  to the right of the frq.
15	Delete	OFF, ON Deletes the selected channel.
16	CopyTo	Copy the channel to another memory.
17	Name	Rename the selected channel. Max. 8 characters. (Only in expert mode.)
18	AM	OFF, ON, Set AM demodulation on the selected channel.

6.2 Radio Config

These settings apply for the entire radio and all channels.

1	Squelch	0 → 9 note that if there are active DxCSS tones the squelch is irrelevant, the moment the radio receives the tone, it activates the loudspeaker, which is very useful in VOX mode, to avoid hearing communications that are not of interest
2	My ID	Radio identity for selective calls. Up to 10 characters and only numbers from 0 → 9 are allowed. Zero stands for NULL = unreachable via selective calls.
3	UpCode	Standard 'DTMF string' that can be prepared and sent by associating it with fast button 1 or 2. The idea is that it can be used to 'switch on' or 'switch off' something. (when there is a parrot with a digital output... it can be done).
4	DwCode	Standard 'DTMF string' that can be prepared and sent by associating it with fast button 1 or 2. The idea is that it can be used to 'switch on' or 'switch off' something. (when there is a parrot with a digital output... it can be done).
5	Call Ch	Set the Call channel. 📞
6	D SideTone	ON/OFF DTMF SideTone. Allows you to listen locally to the tones sent by the radio. (only in TX)
7	BkLi Time	OFF, ON, 5s → 4min Back Light Time: Time for which the display remains illuminated.
8	BkLi Lev	0 → 6 Display backlight level.
9	BkLi TxRx	OFF, TX, RX, TX/RX Determines the event that causes the display to light up.
10	TX TimeOut	6s → 2:30s Time-Out-Timer: Maximum transmission time allowed.
11	Key Beep	Beep when keys are pressed.
12	Tail Tone	OFF, 55, 57.5,60,62.5,65kHz. Final tone so as not to hear others' end-of-transmission rustling.
13	Enables	NONE, PMR TX, Wr Mr, PMR TX + Wr Mr. Enables TX for the PMR446 band and writing to memory channels.
14	Msg Mode	FSK.6, FSK1.2, FFSK1.2, FSK2.4 Messagy mode.
15	L1 Short	Assigns a function to the side buttons on the left (below the PTT).
16	L1 Long	FLASH LIGHT, POWER, Batt Save, BANDWIDTH, SEND UPCODE, SEND DWCODE, Clr SelCall, NONE.
17	L2 Short	"
18	L2 Long	"
19	Batt Save	0 → 4 Battery saving level. It deactivates as soon as it receives a carrier and reactivates a few seconds later. This hysteresis is configurable in PrepperDock.
20	Batt Calib	Calibrating the battery percentage. See chapter 2.4 Flashing Firmware → 14.
21	Batt Text	NONE, VOLTAGE, PERCENT. Type of battery charge status display.
22	Pwr On Msg	NONE, MESSAGE, VOLTAGE. Message when switching on the radio. (Power ON Message)

6.3 Radio FM

Enable FM broadcast radio with the key combination **F + 0 FM**.

The first time the FM radio is started, a complete scan and automatic storage of found channels takes place. Let it finish!

☞ **Listening mode** (without **M** / **MENU**).

▲ ▼ the up and down keys run through the 24 memories.

☞ **Edit mode**, with **M** / **MENU** active = **Modify**

▲ ▼ allow manual tuning or step-by-step correction of the stored frequency.

(M) + 1 Band changes international standards in MHz visible down on the left.

Each time the band changes, the radio restarts the automatic memory scan.

0	87.5 - 108	Europe, America
1	76 - 108	<i>Raramente usata</i>
2	76 - 90	Japan
3	64 - 76	Est Europe, Asia

(M) + 3 MR starts frequency scanning on the memory you are in. Press again **3 MR** if you are not satisfied with the station found. It will be stored automatically, so wait until the end of storage: icon 📶.

* **Scan** Restarts frequency scanning.

(M) + 9 Automatic tuning correction.

⚠ In the FM module, once the **M** / **MENU** is pressed, it remains active until it is pressed again.



6.4 Messagy

Messagy is the form for sending messages.

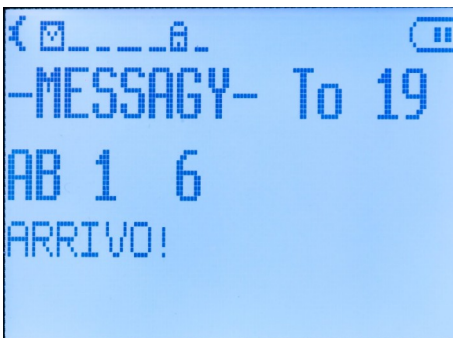

F + M / **MENU** to start Messagy, also from the 'Contacts' section, or go to the menu and select Messagy.

Configure the menus in the **Radio Config** section as follows:

Msg Mode	FSK1,2 (Frequency Shift Key)
-----------------	------------------------------

In PrepperDock > EEPROM > Parameters > Options: Filter Messages → Activated.

Messagy is composed of 3 pages, which can be cycled with the ▼.

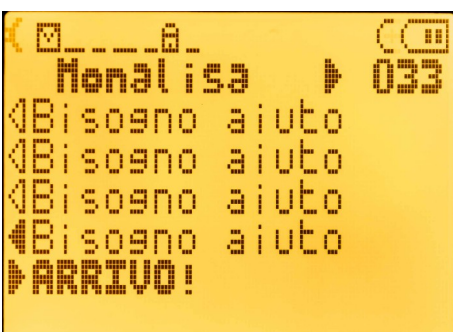

1. **-MESSAGY- To:** writing page, allows messages to be written and sent.
2. **- MESSAGES -:** to view both sent and received messages. In the top right-hand, the ID of the interlocutor.
3. **- SETTINGS -:** Settings can be changed by pressing the button: **M** / **MENU** and * **Scan**.



To....: enter the recipient's identifier.

From..: identifier of the sender. (1 → 254).

Retry evry min: indicate the waiting time between attempts to send the message. In minutes from 1 to 255.

Retry count: Number of attempts to send the message, from 0 to 255. Once an acknowledgement is received, retry stops. Zero keeps this retry function off.

To memorize each change, press the **M** / **MENU**.

To: This ID is different from the My ID of the selective calls, it is intrinsic to the Messagy module. The available addresses are numeric and range from 1 to 254, ONLY with these can the radio give an acknowledgement of receipt (ACK). All radios receive the message, but only the one with the ID equal to **To** will process it and send the acknowledgement. While using 255 will send a message to all, but without receiving an acknowledgement. Since no one will send an ACK, the sender will continue the retries until the end of the count, i.e. if I set 10 retries, all 10 will be executed.

From: It also has nothing to do with the My ID of the selectives calls. Usually once set, it is not changed. The zero stands for NULL so you do not receive messages.



Write the message as described in section 7.1 **Writing Form**, with a maximum of **17** characters.

To send your message, press the **M** / **MENU**.

- MESSAGES - On the second page of the sender, the sent message appears with in the top right-hand, the ID of the interlocutor. On the recipient radio, a letter envelope icon appears in the top left-hand corner. If you consult Messagy, the second page with the received message opens automatically.

When the acknowledgement (ACK) arrives, the white LED lights up for 1 second.

In the display you will see your message on the second page with the full symbol this time.

	Message received.
	Message sent.
	Message sent with acknowledgement of receipt.

From this page you can reply to the received message by pressing **M** / **MENU**. The interlocutor's ID will be transcribed into the "To", automatically moving you to the message writing page. By default the last message is selected, but you can select another one by scrolling through the selection in bold with the **▲** key. Useful if you want to reply to a message sent by another caller.

On the writing page, the messages on page 2 can be made to appear one by one with the up **▲**. This can be useful for returning a message that has not been acknowledged or for not rewriting part of the message and saving time.

Example: < Bye

> Bye, see you soon.

- ◆ Page 2 only transcribes the last 5 messages.
- ◆ Messages remain stored as long as the radio remains switched on.
- ◆ For stable messaging operation, the battery saver must be switched off (Bat Save menu or BatSav Paus). Since, in order to increase battery life, Batt Save listens at intervals, it is sufficient for a DTMF tone or message character to arrive at the time of the interval where the radio does not listen that the entire message or selective call is not considered or is treated with errors.

6.5 Scanny/Spectrum

Scanny

This function is a module in itself. It is not a simple frequency scan. Scanny and Spectrum form a complete module that emulates a real scanner with all its useful functions for effective searching and monitoring.



Example of a scanner unit.

Also accessible with keys **F** + *** Scan**.

Activity:

- = Stop
- = Play
- = Manual Pause
- = Automatic Pause

Activity

Keys 1 and/or 2, 3 and 4 start or stop list scanning .

Resume: choose how the radio should react when it encounters a signal, press the **8 R**.

- **Resume on NO audio:** restarts when there is no longer a signal. The waiting time between the loss of signal and the restart of scanning can be modified in PrepperDock.
- **Resume Wait Time:** stops on the channel for a few seconds and then resumes scanning. This time can be changed in PrepperDock.
- **Pause on audio:** pauses on the found signal.

Set RSSI: **^ v** increases or decreases the RSSI threshold. (Default -95).
(RSSI = Received Signal Strength Indication.)

: **F** + **^ v** up and down arrows, change the scanning direction.

5 Opens the Squelch = Monitor. A loudspeaker appears on the right.

0 FM temporarily excludes or re-enables a frequency. The limit is 214 channels and 32 frequencies per band. An X appears to the right of the excluded channel. (**0 FM** = Frq Muted)

F + **4 FC** you get the **Fast Copy** function (Frequency Meter).

Analyses and identifies the frequency and CTCSS tone of a transmitter. It is necessary that the 2 radios are VERY close together, almost in contact, because the signal must be strong.

After that, Scanny returns to the main screen with the frequency found and stored in the first empty channel it finds.

M / **MENU** = pause/play.

In Pause certain keys acquire different functions.

- **^ v** forwards or backwards by one channel or frequency.
- **PTT** copies the frequency found to the main screen. If it is a channel, it takes you directly to it, whereas if it is a frequency, it automatically creates a channel in the first empty memory it finds by naming it with the memory number, e.g: CH-102.

F + **3 VFO/MR** switches from Channel mode to Frequency mode and vice versa.

In Frequency mode, you must first set the bands and groups to be scanned with PrepperDock. Refer to chapter **2.3.4 Frq Scan** of the user-manual-PrepperDOCK.pdf manual.

The display will show Step 0:0. The first zero corresponds to the first band of the selected group, even if in PrepperDock the band is 3, the start is always 0 then 1, 2, etc. The second zero will show the Step of the band at which the scan is located.

Spectrum

The Spectrum is accessed from Scanny by pressing *** Scan**.

The Spectrum is another way of scanning with a more graphic interface, but with a different behaviour.

Most button functions are identical to Scanny except for RSSI adjustment and change of scanning direction.

Each column of pixels in the Spectrum corresponds to a channel or frequency step.

The screen is able to display a maximum of 128 columns, so if the number of channels or frequencies is 128 or less, these will be shown in its width and scanned continuously. Whereas if they exceed 128, Spectrum will only scan a slice of the 128 visible. In order to scan the rest, while in Play, move with the arrows **^** **v**. The spectrum will move in steps of 32 columns, showing the new ones and hiding the former.

When paused, you can move the cursor manually in this 128-column slice with the keys **^** **v**.

◆ To exit Scanny or Spectrum press the **EXIT**.



6.6 Contacts

It is an address book with 32 contacts, useful for making selective calls and as group identifiers. Also accessible with **F** + **9 Call**. (chapter 7.2).

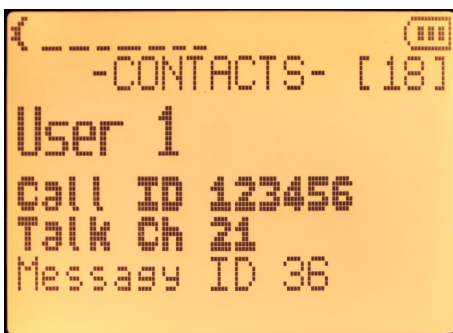

1. On the first line you write the name of the contact, maximum 10 characters.
2. In the second, called **CALL ID**, write a numeric identifier for the radio, the 'My ID' of the contact, maximum 10 digits. If 10 digits are used, the first character cannot be more than 3.
3. Third line, called Talk Ch: enter the number of the channel into which you would like to move the communication.
4. On the fourth line write the Message ID, between 1 and 254.

M / **MENU** To modify and memorize the change. Press it for each modified line.

***** to move on to the next line.

PTT To make a selective call to a single user.

9Call To make a group call.

F + **M** / **MENU** To send a message to the contact with Messagey.

A contact can also be a group

When a radio receives a DTMF with a # after the ID (receiver) number, it perceives it as a group. In practice, the radio searches for this number in the contact list and if it is present, the radio rings, because it belongs to that group. So it is necessary to create a contact with an ID intended for that and call it e.g. Group1. (See Chapter 7.2.2)

6.7 Timer

Timer is a countdown-based clock radio.

Enter the time by typing complete 4-digit numbers, e.g. to write 7:30, type 0730.

To store the chosen time, press **M** / **MENU**



* Choose the type of ring tone between alarm or FM radio. In the case of FM radio, Timer will tune to the frequency last heard.

Start the timer with the key **^**.

Stop the timer with the key **v**. *These two lines are informative only, not editable.*

EXIT returns to the main screen, but in the background, the timer continues to run.

6.8 Info

Shows radio data, firmware version, hardware and other information.

The **v** key scrolls through the other pages.

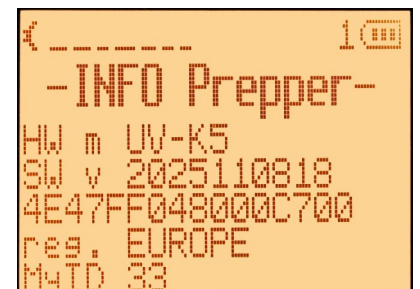

7. Common operations

7.1 Writing module

Text can be written in various sections of the radio, such as Message, Contacts and Name. The writing module works like this:

- The writing field is always located at the bottom where a cursor flashes.
- Above is a string with three pieces of information, from left to right:
 1. Indication whether in upper case: **AB**, lower case: **ab** or numeric: **09**.
To switch between modes, press the *****. This button also allows you to edit the other fields.
 2. Reports the key that was pressed last.
 3. Shows the number of characters already written.

The alphabet is distributed as on the T9 keyboards typical of 90s mobile phones.

<ul style="list-style-type: none"> • 1 , . ? ! ' : () • 2 A B C @ a b c / • 3 D E F * d e f % • 4 G H I + g h i < • 5 J K L - j k l = • 6 M N O & m n o > • 7 P Q R S p q r s • 8 T U V t u v • 9 W X Y Z w x y z • 0 Confirm and move on to the next letter if it is in the same key. • Pressed twice = space. • To delete a letter, press the side key L1 	
---	--

7.2 Selective Call

There are two types of channels in the PrepperRadio firmware, the **Call Channel** and the **Talk Channel**. The Call Ch serves only as a meeting point for radio contact via a selective call. When the receiver answers, you move to another channel and then you can talk, the Talk Ch.

7.2.1 How to make a selective call (calling only a specific radio).

It is assumed that the two radios have the same firmware, the same address book, the same band plan, with the same 'Call' channel, identical frequency, subtone and other settings.

Menu setting example.

So we go to the menu Radio Config → My ID, press **M** / **MENU** and enter an identifier, e.g. 1 on the first radio and 2 on the second. (0 stands for NULL = unreachable via selections).

Make sure that both radios are on the same 'Call' channel, then menu Radio Config → Call Ch, channel 9. You can quickly select this channel with the **F** + **4FC**. DTMF decoding must be activated on this channel: Channel Config → D Decod : ON.

Menu RADIO 1	Menu RADIO 2
My ID = 1	My ID = 2
Call Ch = 9	Call Ch = 9
Channel Config → D Decod su ON sul canale Call	

At this point we go to Menu Contacts and enter this data.

Editing the Contacts section:

Choose the contact to be edited, then press the **M** / **MENU** (edit) and enter a nickname as described in section '7.1 Writing Form'. Continue pressing the ***** more than 3 times switches to the change of the identifier, to save the change press the **M** / **MENU**. Repeat the operation also for changing the Talk Ch channel.

To memorize each change, still press the **M** / **MENU**.

Radio 1 caller:

Name: Radio2 → *This name does not affect calls, it only serves as a mnemonic reference.*
ID: 2 → *It corresponds to the My ID of the receiver.*
Talk Ch: 88 → *It may be different, because it is the caller who decides on the conversation channel.*

Radio 2 receiver:

Name: Radio1
ID: 1
Talk Ch: 88

Now go to the Contacts menu of Radio 1, select Radio 2 with the arrows and press **PTT**. A selective call starts and is received by radio 2, which starts to ring like a telephone. The name of the caller will appear on the last line to the right.

To answer, radio 2 must press the **PTT**. Radio 2 transmits an acknowledgement signal to radio 1 and they both move to channel 88.

Now we can talk quietly on chosen channel 88.

At the end of the chat, after 15 seconds, the radios automatically return to the Call channel.

If you are not present during a call, the radio will display the time elapsed since the last call attempt in a counter at the bottom of the screen, consisting of hours, minutes and seconds.

- ◆ Talk channel 88 is an example, what matters is that it is configured in exactly the same way on both radios, same number, frequency and subtone. Subtones allow you to be sure that there is no interference; this silence is used by the radio to realize that the call has ended and automatically return to the Call channel. The delay to return to the Call Ch. is adjustable from PrepperDock.
- ◆ This firmware can store 32 contacts in the phone-book, but calls can also be made manually.

7.2.2 Selective Group Call

This type of selective is used to call a group of people.

The goal is to notify a group of radios that a call is to be made. A 'group' is defined as a set of radios having a 'contact' with the same ID in the Contacts section. This ID becomes the ID of the group, superseding the My ID of a specific radio.

It is therefore the ID field in the Contacts section that will address the group call. This group ID must be unique and different from all My IDs on the radios. On the call, a channel change is not implemented, but a ringing alert is given.

Example of contact-group to be included in all radios:

Name: Group A (9) → *This name does not affect calls, it is only for you.*
ID: 411 → *Unique ID of the group.*
Talk Ch: 88

So far everything is identical to a single contact. But to call this group and reach several radios at a time, press the **9Call**, (instead of PTT).
(Adds the character # to the DTMF string after the recipient's ID).

Mnemonics: 9 is the largest digit on the keyboard, like a group of people, and inside the word Call there is 'all'.

The second trick is to add after the group name (9), this will remind you of the button to press to call the group.



Illustrative videos: Chiamata Selettiva uno a uno:

<https://odysee.com/ChiamataSelettiva-1-a-1:b?r=H1SPCWjv2TqR2kqnKP42NCRUoVdwuyLk>

7.3 DTMF

*** Scan** in the main screen activates the string to enter a DTMF sequence. A > sign appears to the left indicating the start of the string.

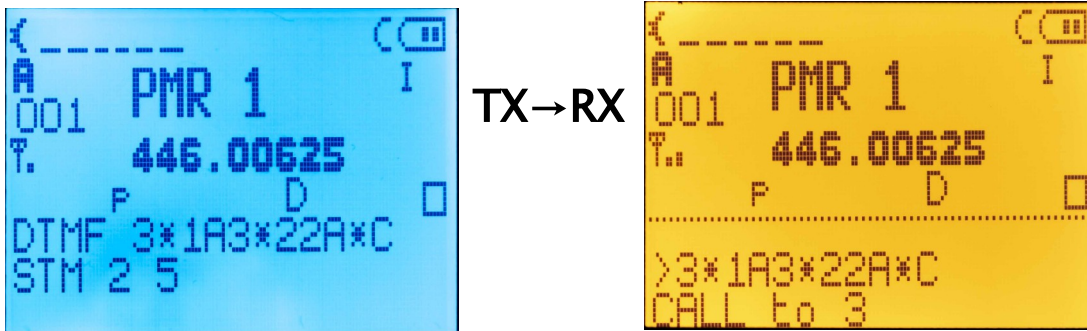

The characters allowed in DTMF are 0123456789 ABCD * #.

M / **MENU** = **A**, **^** = **B**, **v** = **C**, *** Scan** = *****, **F** = **#**.

L1 = deletes 1 character. **PTT** = sending the sequence.

- The symbol * is generally used as a 'field separator'.
- The # symbol is somehow associated with 'group' management.
- Identifiers are generally numeric.
- Letters are used to attribute special meanings to the data passing through.
- Command lines must always be terminated by A*.
- On the receiver, in addition to the DTMF code, the result of the 'state machine' appears (possible debug codes to report if you have problems).

8. Practical usage

8.1 How to get organised

Like any emergency tool, it's not enough to have it at home and be safe, you have to know how to use it well before the emergency.

One of the methods we propose is to organise in advance into groups of people, by neighbourhoods, villages or areas where radios can communicate, and to rehearse from time to time.

That is why we propose to read the procedure in the Home called user-manual-Come_organizzarsi-EN.pdf.

Stay calm and switch on the radio!



L'ABC DELLA RADIO



<https://t.me/+3S1rKwPf-2AxMTJk>

Donate with

